



1/2"x7" Single End Stud

6310807

Units Inch[mm]

Scale 1 / 2

Drawn Shannon Kimes

Date 3/21/2026

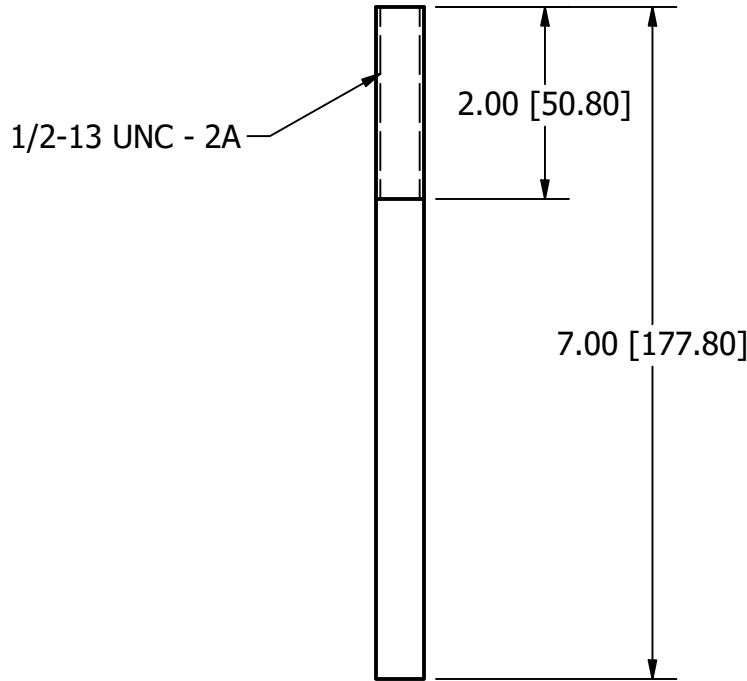
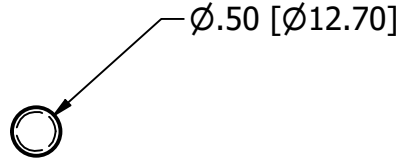
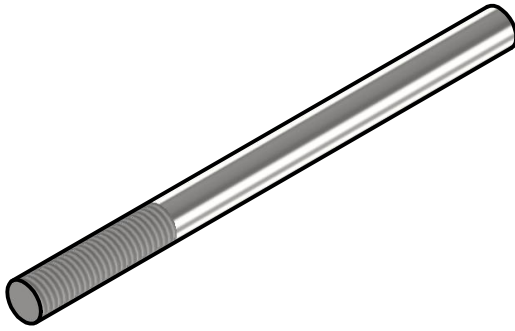

Material		Packaging		Notes
Base Material: Steel, Carbon		Weight lbs[kgs]	Units	1. Weights approximation/theoretical.
Finish: Plain/None	Piece	0.37[0.17]	1 Piece	
Coating: Oiled	Bag	50[23]	135 pcs	
	Pallet	2500[1134]	50 Bags	
	Ton[MT]	2,000[1,000]	5405[5946] pcs	